

Pos. Nr.	Text	Art.-Nr.	Preis-gruppe
1	Kupplungskopf (4 Stk.) Coupling head (4 pc.) Tête d'attelage (4 pièces)	40270	20
2	Schraube 2,2x6,5 Screw 2,2,x6,5 Vis 2,2x6,5	85800	2
3	Zugfeder Spring Ressort de rappel	86208	2
4	Lokführer Loco driver Mécanicien	89732	5
5	Glühlampe rot Lamp red Ampoule rouge	89889	13
6	Glühlampe 12 - 14 V Lamp 12 - 14 V Ampoule 12 à 14 V	93519	10
7	Innenbeleuchtung komplett Lighting set Eclairage intérieur complet	95804	35
8	Platine komplett Printed circuit assembly Circuit imprimé complet	95815	40
9	Stirnfenster vorne Front window front Pare-brise avant	95839	3
10	Übergangsfenster Front door window Baie porte d'intercirculation	95841	3
11	Lichtleiter Light transmission bar Conduite de lumière	95842	3
12	Rahmen Frame Chassis	108054	40
13	Kupplungsdeichsel Coupling Timon d'attelage	108056	3
14	Inneneinrichtung Interior Aménagement intérieur	108057	18
15	Bodensteckteil Frame push in part Complément chassis	108058	3
16	Gehäuse komplett f. 43037 Betr. Nr. X 2732 Body assembly f. 43037 Nr. X 2732 Caisse complet p. 43037 N° X 2732	108061	57
17	Breiter Pufferteller Buffer short Plateau large de tampon	108069	3
18	Puffersockel Buffer base Boisseau de tampon	108075	3
19	Schmäler Pufferteller Buffer small Plateau étroit de tampon	108076	3
20	Fenstersatz Window set Jeu de fenêtres	108077	15
21	Führerstand Cab Cabine de conduite	108078	3
22	Faltenbalg Bellows Soufflet d'intercirculation	108079	3
23	SNCF-Schild SNCF-plate Plaque SNCF	108080	2
★24	Gehäuse komplett f. 43037.1 Betr. Nr. X 2730 Body assembly f. 43037.1 Nr. X 2730 Caisse complet p. 43037.1 N° X 2730	108086	57
★25	Gehäuse komplett f. 43037.2 Betr. Nr. X 2728 Body assembly f. 43037.2 Nr. X 2728 Caisse complet p. 43037.2 N° X 2728	108088	57

3 o. Abb. / no ill. / non figuré  
Zugfeder  
Spring  
Ressort de rappel

Pos. Nr.	Text	Art.-Nr.	Preis-gruppe
1	Motor komplett (ohne Schrauben) Motor assembly (without screws) Moteur complet (sans vis)	85036	57
2	Haftlingsatz Traction tyre set Jeu de bandages d'adhérence	85622	19
3	Schraube M 2x4 Screw M 2x4 Vis M 2x4	85670	2
4	Schraube M 1,6x5 Screw M 1,6x5 Vis M 1,6x5	85692	2
5	Beilagscheibe Washer Rondelle	86084	2
6	Zahnrad z=16R Gear z=16R Pignon z=16R	86435	3
7	Lagerbock Bearing pedestal Palier	95809	3
8	Kardanwelle 29,2 mm Cardan shaft 29,2 mm Arbre à Cardan, 29,2 mm	95810	3
9	Kardanwelle 28,2 mm Cardan shaft 28,2 mm Arbre à Cardan, 28,2 mm	95811	3
10	Kardanschale Cardan bearing Tulipe du Cardan	95812	3
11	Welle 2G 5x60,5 Axle 2G 5x60,5 Axe 2G 5x60,5	95820	8
12	Getriebegehäuse vorne Gear housing front Carter bogie avant	95821	12
13	Kardanwelle Cardan shaft Arbre à Cardan	95823	3
14	Radkontakt Wheel contact Palpeur	95827	3
15	Schneckensatz Worm set assembly Jeu de vis sans fin	95828	24
16	Schneckendeckel Worm cover Couvercle de la chambre de la vis sans fin	95829	3
17	Getriebegehäuse hinten Gear housing rear Carter bogie arrière	95830	12
18	Triebdrehgestell vorne m. Haftringen Bogie assembly front w. traction tyre Bogie moteur avant avec bandages	108059	50
19	Triebgestell hinten o. Haftringe Bogie assembly rear without traction tyre Bogie moteur arrière sans bandages	108060	50
20	Getriebefoden vorne Gear cover front Couvercle du carter bogie avant	108068	12
21	Blende vorne Bogie frame front Flancs du bogie avant	108070	10
22	Getriebefoden hinten Gear cover rear Couvercle du carter bogie arrière	108072	12
23	Getriebeplättchen Gear plate Plaque support du carter	108073	3
24	Blende hinten Bogie frame rear Flancs du bogie arrière	108074	10
25	Radsatz mit Haftringen Wheelset with traction tyre Essieu à roues bandagées	108096	20
26	Radsatz ohne Haftring Wheelset without traction tyre Essieu à roues bandagées	108100	18

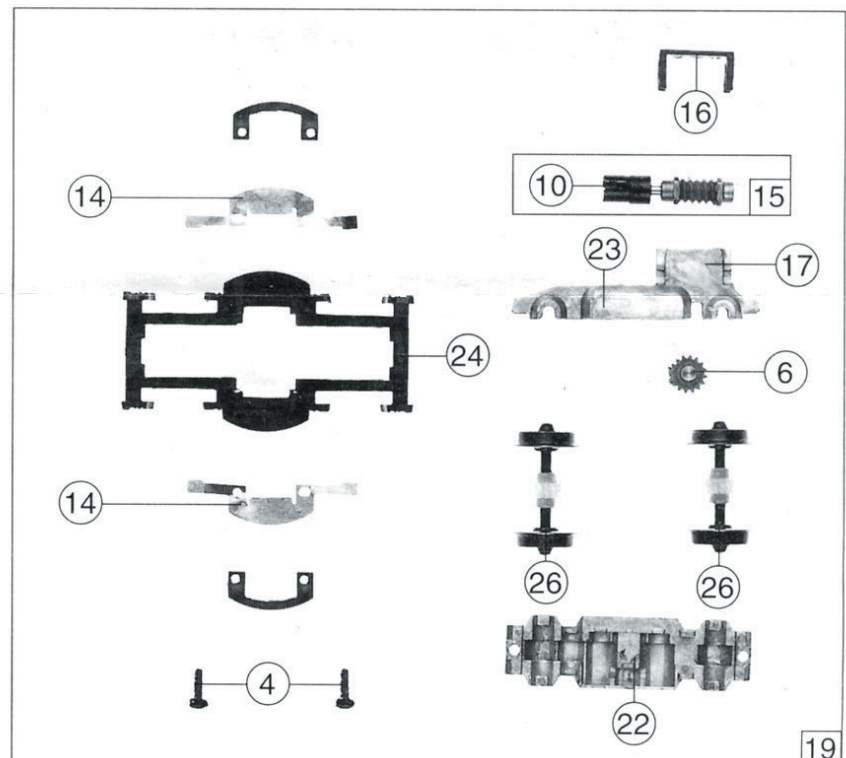

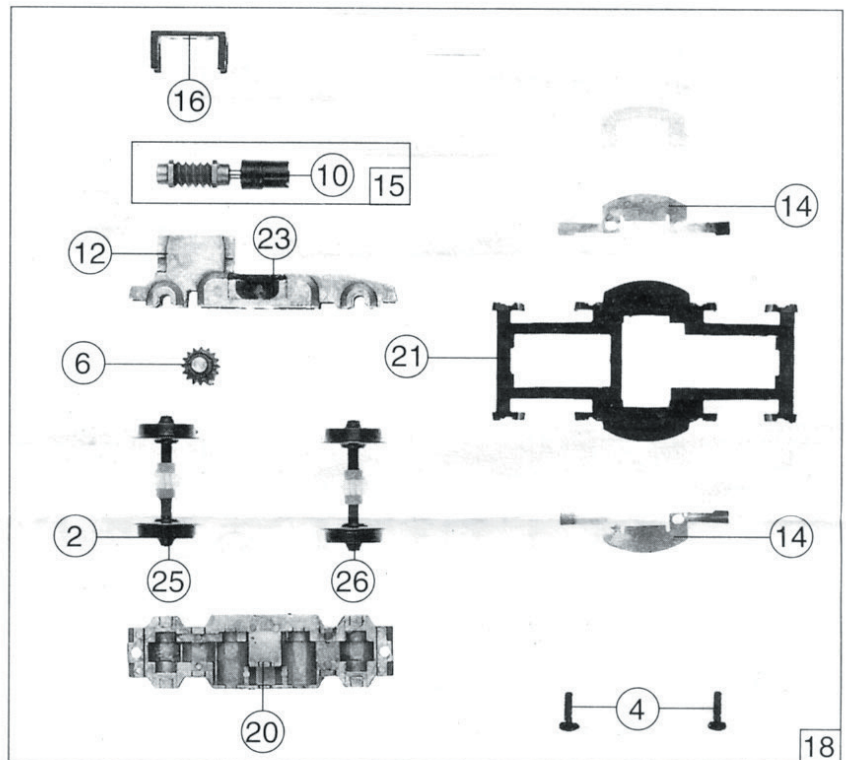
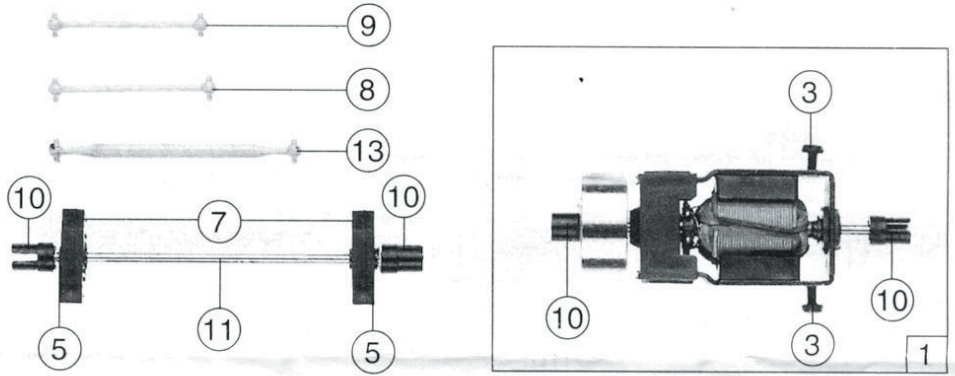
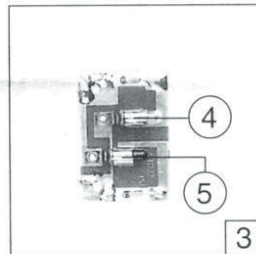
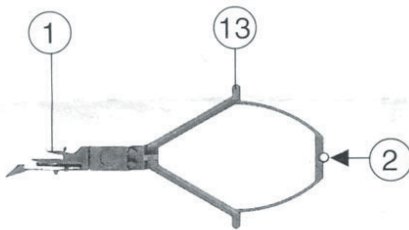
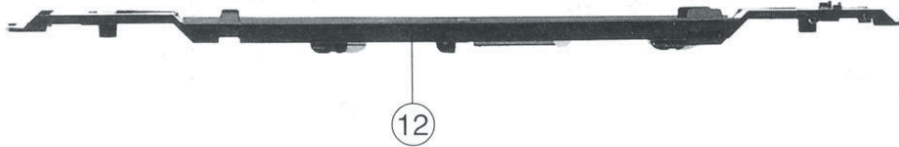
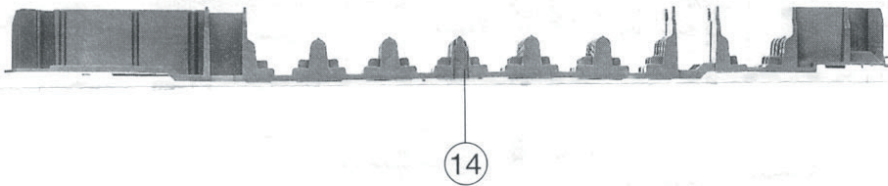
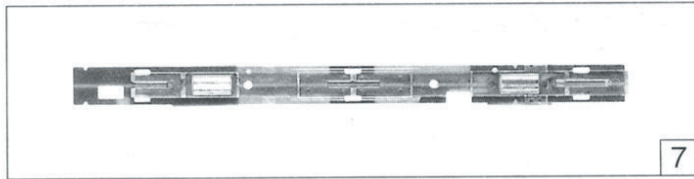
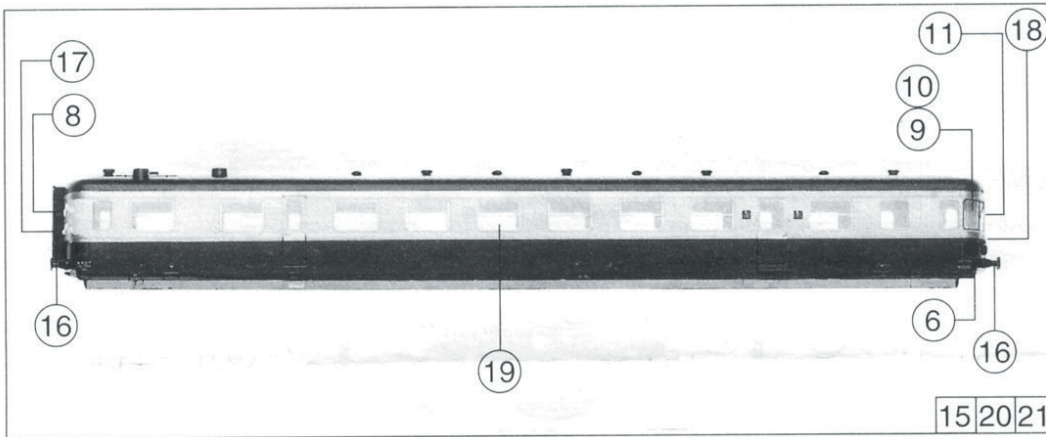

Pos.-Nr.	Text	Art.-Nr.	Preis-gruppe
1	Kupplungskopf Coupling head tête d'attelage	40270	20
2	Zugfeder Spring Ressort de rappel	86208	2
3	Platine komplett Printed circuit assembly Circuit imprimé complet	87729	30
4	Glühlampe 12 - 14 V Lamp 12 - 14 V Ampoule 12 à 14 V	93518	12
5	Glühlampe Lamp Ampoule	93522	14
6	Lichtleiter Light transmission bar Conduite de lumière	95800	3
7	Innenbeleuchtungssatz Lighting assembly Éclairage intérieur complet	95804	35
8	Stirntürfenster Front door window Fenêtre de la porte d'intercirculation	95841	3
9	Stirnfenster links Front window left Baie gauche de la cabine de conduite	95849	3
10	Stirnfenster rechts Front window right Baie droite de la cabine de conduite	95850	3
11	Stirnfenster mitte Front window middle Baie centrale de la cabine de conduite	95851	3
12	Bodenplatte Bottom plate Chassis	108062	23
13	Kupplungsdeichsel Coupling Timon d'attelage	108063	3
14	Inneneinrichtung mit Küche Interior Aménagement intérieur	108064	18
15	Gehäuse komplett f. 43037 Betr. Nr. X R 7732 Body assembly f. 43037 No. X R 7732 Caisse complète p. 43037 N° X R 7732	108067	57
16	Puffer schmal Buffer small Tampon à petit plateau	108076	3
17	Faltenbalg Bellows Soufflet	108079	3
18	Stirnabdeckung Front cover Carénage frontal	108083	18
19	Fenstersatz Window set Jeu de fenêtres	108084	15
★20	Gehäuse komplett f. 43037.1 Betr. Nr. X R 7730 Body assembly f. 43037.1 No. X R 7730 Caisse complète p. 43037.1 N° X R 7730	108087	57
★21	Gehäuse komplett f. 43037.2 Betr. Nr. X R 7728 Body assembly f. 43037.2 No. X R 7728 Caisse complète p. 43037.2 N° X R 7728	108089	57

Pos. Nr.	Text	Art.-Nr.	Preis-gruppe
1	Getriebe Nachrüstsatz Gear expanding set Jeu d'engrenage complémentaire	86488	33
2	Radkontakt Wheel contact Palpeurs	95827	3
3	Zurüstbeutel Bag with accessories Sachet de pièces de finition	108052	18
4	Drehgestell komplett Bogie assembly Bogie complet	108066	38
5	Kontakthaltersatz Contact holder set Support des palpeurs	108071	11
6	Drehgestellrahmen Bogie frame Flancs de bogies	108082	10
7	Radsatz Wheelset Essieu	108081	16

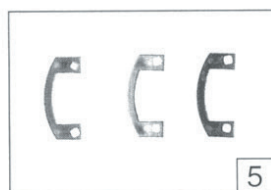
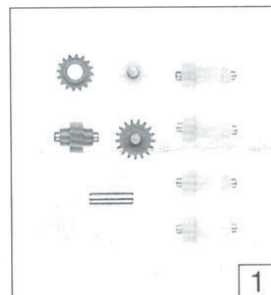
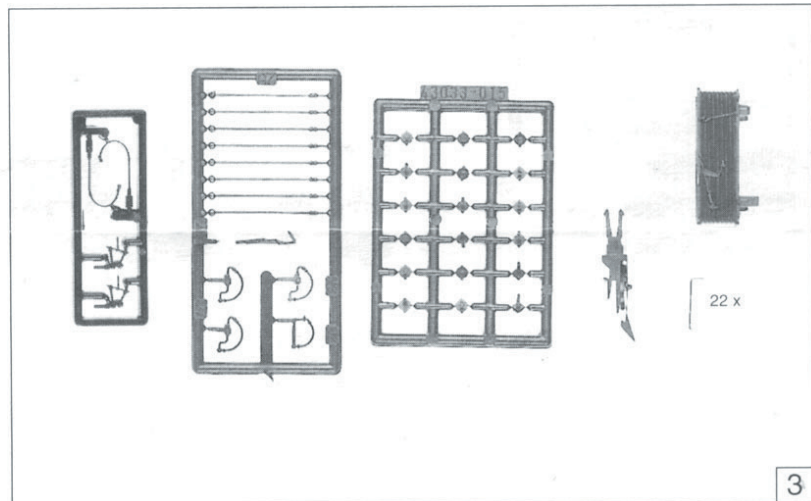
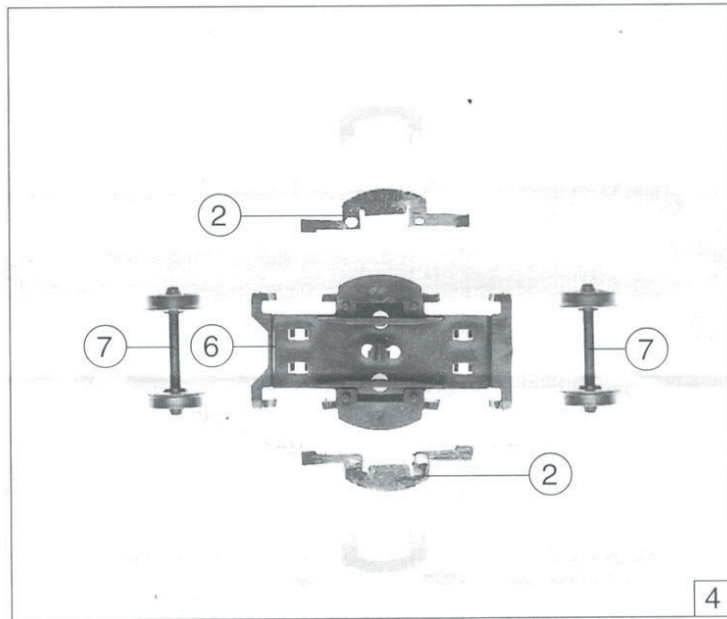

Getriebe Nachrüstsatz  
 Gear expanding set  
 Jeu d'engrenage complémentaire

damit kann die 2. Achse pro Drehgestell angetrieben werden  
 to drive the 2nd axle  
 permet de motoriser le 2<sup>e</sup> essieu des bogies moteurs